



**Fabric Roller Tube Assembly
with Universal Hardware**

USA
SERVICE OFFICE
The Dometic Corp.
509 So. Poplar st.
LaGrange, IN 46761

CANADA
Dometic Dist
866 Langs Dr.
Cambridge, Ontario
CANADA N3H 2N7

OPERATING INSTRUCTIONS

MODELS

8000
8500
9000

TO OPEN

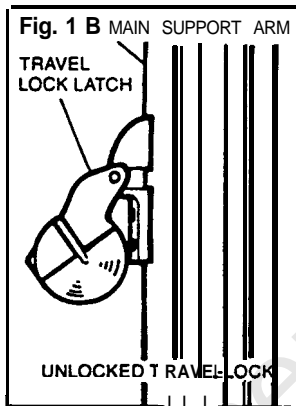
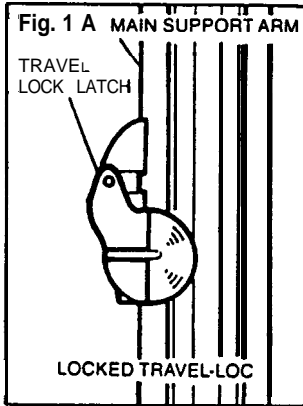

1. Loosen the Adjustment Lock Knob (located behind the Main Arm). Flip Travel Lock up. (Fig. 1A & 1B)

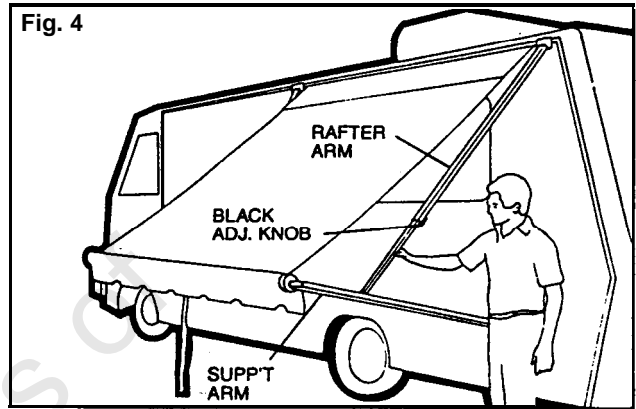

4. From the side of either Arm Assembly, slide Rafter Arm up the Support Arm until it snaps into place over the Slider Catch, located at the top of Support Arm. Place downward force on Main Support Arm to remove slack from fabric and tighten Black Adjustment Knob on the Rafter Arm. Repeat for other side. Fig. 4.

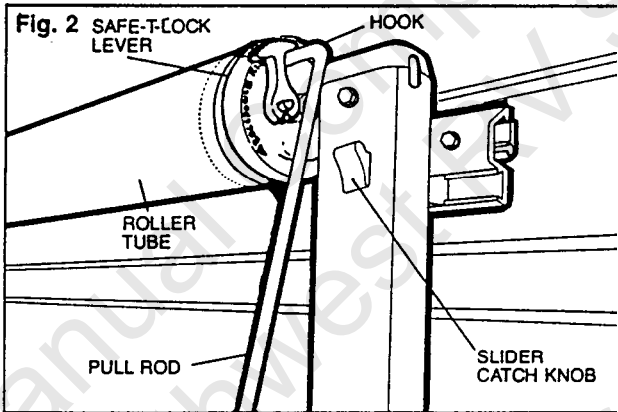

2. Locate Safe-T-Lock Lever on the right end-cap of the Fabric RollerTube Assembly. Place the Hook of the Pull Rod on Lock Lever and pull Lever forward into the ROLL DOWN position. Fig. 2.

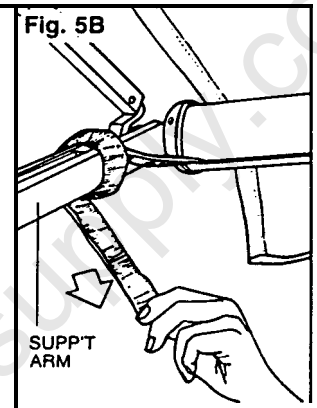
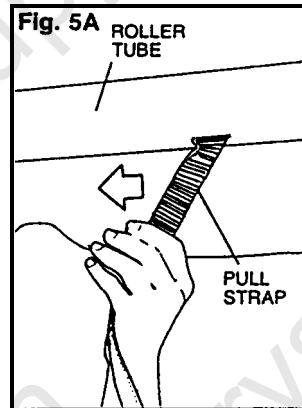

5. Reposition Pull Strap out of the way by sliding it down the Fabric Roller Tube Assembly toward the right (same end as the Safe-T-Lock). Wrap the Strap around the Main Support Arm. Figs. 5A & 5B.

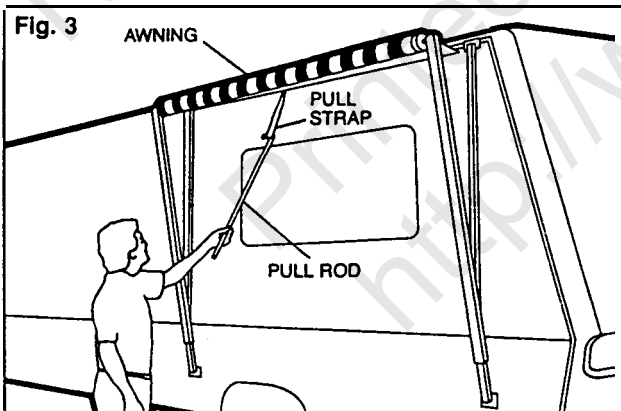

3. Insert Hook of the Pull Rod through the loop of the Pull Strap. Pull the Strap outward and completely extend Awning. The Awning will now stay positioned by itself. Fig. 3.

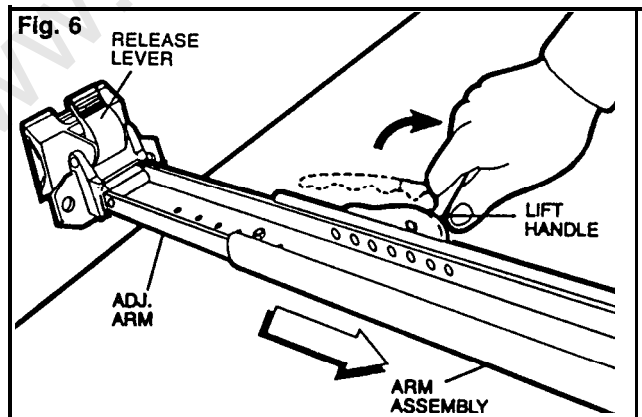

6. To raise Awning, simply pull up on Lift Handle (which automatically releases the Lock Button), and lift the Arm Assembly. When desired Awning height is reached, swing Lift Handle inward and allow Lock Button to snap into a pre-punched hole in Adjustable Arm. Extend other Arm Assembly to same height. Fig. 6.

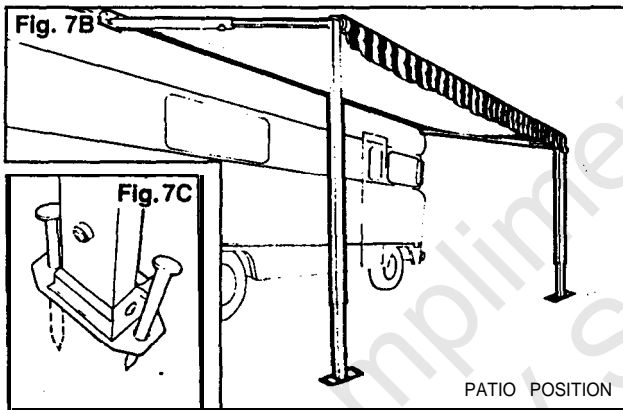
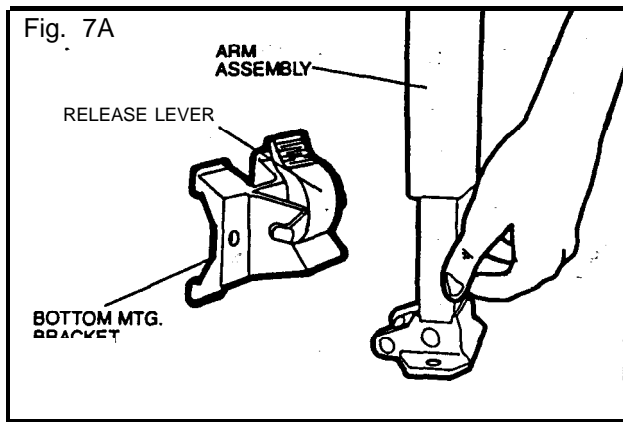

7. For extended stays and where ground conditions permit, the Patio Position allows easier access and more usable space. Fig. 7B

Locate Release Lever in the center of the Bottom Mounting Bracket and depress. Grasp Arm Assembly and pull straight out and off Bracket. Swing Arm out to a vertical position and readjust height. Secure by driving provided Stakes through holes of the Patio Foot and into the ground. Figs. 7A & 7C.

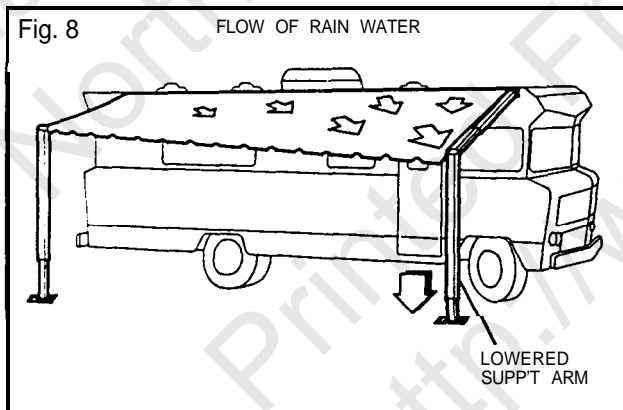

8. The Automatic Water Release must be set during rain to prevent damage from water build-up. To set, simply lower one of the Support Arms enough to create down slope toward that side. Fig. 8.

CAUTION: Whenever heavy or prolonged rain or wind is anticipated, or you will leave the Awning unattended, it is best to close Awning. Damage as a result of weather is not covered by warranty.

TO CLOSE

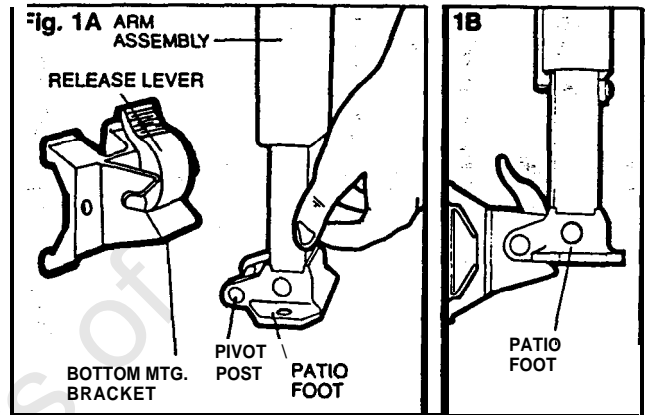

1. **From Patio Position:** Pull Stakes from Patio Foot and swing Arm back toward Bottom Mounting Bracket. Place the pivot post of the Patio Foot in the Receptacle of the Bottom Bracket and press firmly in toward vehicle and allow Patio Foot to interlock with Bracket. Repeat for other side. Figs 1A & 1B. Proceed with Step 2.

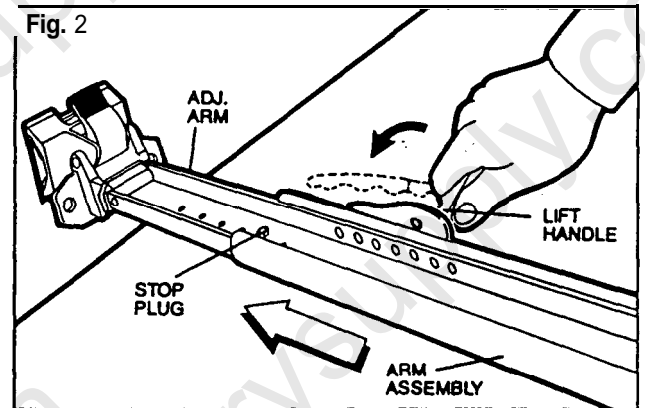

2. **From Vehicle Mounted Position:** Raise Lift Handle, releasing Lock Button, and Lower Main Support Arm down to the Stop Plug. Ensure Lock Button snaps into a pre-punched hole in the Adjustable Arm. Fig. 2.

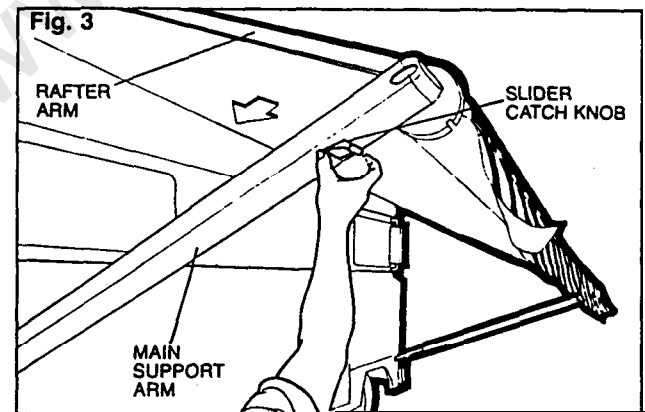

3. To release Rafter Arm, loosen Black Adjustment Knob on the Rafter Arm and lift up on the Slider Catch, located on the top front of Main Support Arm. Slide Rafter Arm down to the bottom of the Main Arm. Do not retighten Adjustment Knob at this time. Fig. 3.

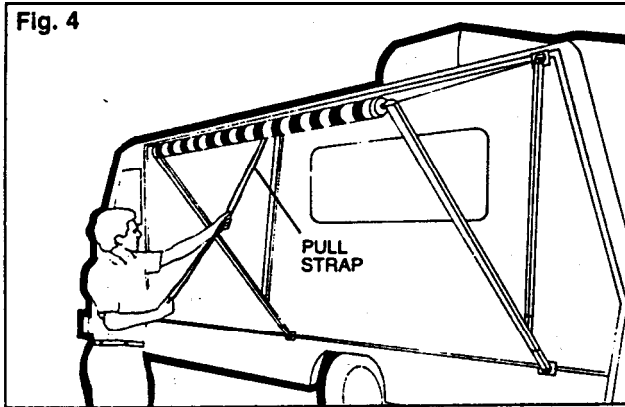

4. Prepare Fabric Roller Tube Assembly for roll-up. While pulling down on the Pull Strap or while, from the bottom, turning the entire Roller Tube toward you slightly, flip the Safe-T-Lock Lever into the ROLL UP position.

CAUTION: Do not release the Awning as it is now under tension and could snap back against vehicle side.

Slide Pull Strap to the middle of Awning and, using Strap for control of speed and even roll-up, allow Awning to return to the vehicle side. Fig. 4.

NOTE: Allow Strap to return diagonally to avoid creating a bulge in the Awning Fabric.

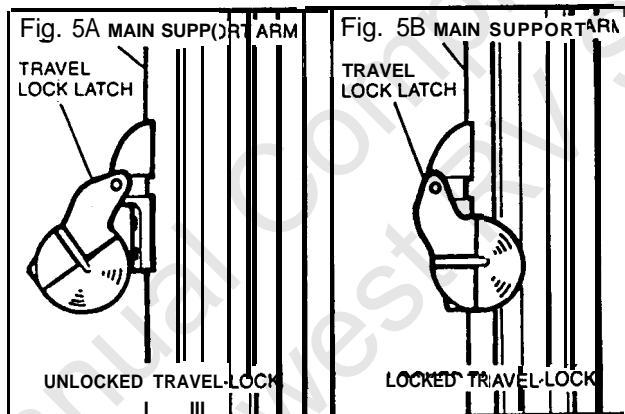

5. **To Secure Awning for Travel.** For added security and rattle-free travel, tighten Adjustment Lock Knob. Flip Travel Lock down into locked position. (Figs. 5A & 5B)

Make sure Latch is securely in place, then repeat for remaining arm.

The awning is now secure and ready for travel.

OWNER MAINTENANCE ITEMS

1. Make sure the top and bottom bracket screws are tight at the start of each camping season.
2. Lubricate the rafter arms and support arms using paraffin wax or silicone spray. Also lube the threads on knobs.

3. Periodically clean the awning fabric as follows: 8000/8500 use a mixture of 1/4 cup of dish soap and 1/4 cup of bleach mixed with 5 gallons of warm water. Liberally slosh this mixture on the top of the fabric then roll the awning up for 5 minutes. This will apply the mixture to the bottom as well. Roll back out and hose off with fresh water. Repeat if necessary. Allow to dry before rolling back up. FOR 9000 ACRYLIC FABRIC – Periodically hose off the fabric with water then let it air dry completely before rolling it up. The acrylic material of the 9000 awning is water repellent, not water proof. The fabric is pre-treated with a water retardant finish. Reapplication of a water retardant spray is recommended once a year.

4. Mildew cannot form on the fabric, but rather will form on dirt or dust on the fabric. The key is to keep the fabric clean.

5. To remove grease spots from fabrics 8000/8500 (vinyl) use only a soap and water solution. Avoid use of caustic household cleaners, mildew removers or hard bristle brushes. On 9000 fabric (acrylic) use K2R spot remover.

6. Occasionally the 8000 fabric may develop a pinhole, actually a spot of paint flaked off from the top layer of vinyl. This may be quickly remedied with a very small dab of VLP (Vinyl Liquid Patch) on the tip of a Q-tip® by gently rolling around the pinhole the VLP will melt the paint (in the stripe) and that will quickly fill in the pinhole with a perfect match. Be sure to wait until the VLP sets before rolling up the awning.

7. If you get water streaking or seeping behind awning rail, inspect the awning rail for loose screws or peeled sealant.

8. Always make sure the awning is extended high enough before opening entry door.

9. Lower one end of awning for proper water run off and to avoid water pooling.

This Manual is Compliments of

Northwest RV Supply

86325 College View Road
Eugene, OR 97405

Local: 541-746-9092

Toll-Free: 866-678-7467

Fax: 541-736-5573

<http://www.nwrvsupply.com>
mail@nwrvsupply.com

Northwest RV Supply carries a large spectrum of surplus, used, and new RV parts and components. Please feel free to visit our website for additional information.