

# EuroVan Camper

# SIDEWINDER II

## INSTRUCTIONS

052813-104

THIS MANUAL CONTAINS SECTIONS FOR:  
SAFETY, INSTALLATION, OPERATION, CARE AND  
MAINTENANCE AND WARRANTY

**READ ENTIRE INSTRUCTIONS BEFORE BEGINNING  
INSTALLATION. FOLLOW ALL CAUTIONS,  
WARNINGS AND NOTES TO PREVENT INJURY OR  
DAMAGE TO AWNING OR VEHICLE.**

### TOOLS AND SUPPLIES REQUIRED

Drill, 1/4", 1/8", 3/8", 11/64" & 13/64" Drill Bits  
10mm Socket/Nut Driver  
Straight Blade Screw Driver, Phillips Screw Driver

## SECTION I: SAFETY INFORMATION

**CAUTION:** Means a hazard that may cause minor or moderate injury if the warning is ignored. It also may mean a hazard that will cause damage to property.

**CAUTION:** GROUND STAKES WILL NOT PREVENT THE AWNING FROM MOVING IN THE WIND!

**CAUTION:** ONCE THE FLIPPER LATCH IS RELEASED, THE SUPPORT ARM WILL WANT TO SLIDE DOWNWARD QUICKLY. TAKE CARE TO KEEP HANDS AWAY FROM ANY POSSIBLE PINCH POINTS WHEN LOWERING SUPPORT ARM!

### INSTALLATION PREPARATION:

- The EuroVan Camper Sidewinder II mounts with special brackets designed specifically for the EuroVan Camper. Carefree's part number for these brackets is 906003. These brackets must be used for installation on a EuroVan Camper.

## SECTION II: SIDEWINDER II INSTALLATION

- Attach small awning rail sections to the top holes of brackets with the M6 x 16 slotted pan head screws, washers and lock nuts provided. Make sure the slot of the rail is facing downward.
- Position the brackets on the vehicle in the locations shown below. The front one on the door post and the rear one just behind the rear window.

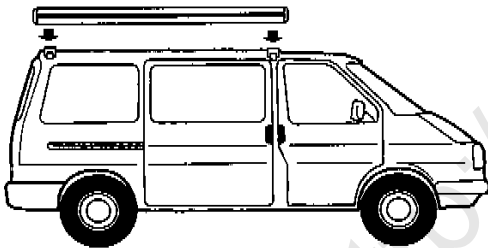

- Set the brackets so that the underside of the bracket is placed 10mm above the roof edge. **NOTE: THE FRONT BRACKET MUST BE POSITIONED ON THE DOOR POST BETWEEN THE SLIDING DOOR AND THE FRONT PASSENGER DOOR. MAKE SURE THAT IT DOES NOT INTERFERE WITH DOOR OPERATION! POSITION BACK BRACKET JUST BEHIND THE REAR SIDE WINDOW.**

For installation assistance call Carefree Customer Service  
1-800-621-2617

## SIDEWINDER II INSTALLATION (cont.)

- Mark the mounting holes as shown right.

- Drill a 1/8" pilot hole in the three previously marked locations.

- Drill the 1/8" pilot holes out to 3/8".

- Place a jacknut in each of the three 3/8" holes.

- Drill a 1/4" hole in each of the supplied rubber plates.

- Remove the paper backing from the rubber plates. Line up the holes with those in the brackets and stick the rubber plates to the back of the brackets.

- Position brackets over holes and thread the M6 x 25 bolts into the jacknuts. Tighten until snug using a 10mm socket.

**NOTE: IF THE JACKNUTS TURN LOOSE, BACK BOLTS OUT AND PLACE A SERRATED LOCK WASHER BETWEEN THE JACKNUTS AND THE BRACKETS INSTEAD OF THE RUBBER PLATES AND TIGHTEN DOWN. ONCE TIGHT, REMOVE BRACKET AND RE-INSTALL USING THE RUBBER PLATES.**

- To support the awning in the center, place the rubber spacer between the back of the awning case and the vehicle. To do this, drill a 13/64" hole in the back center of the case and attach using the M5 x 16 slotted head bolt, nut and washer provided.

- Slide awning case onto brackets by sliding the extruded bead on the top of the case into the previously installed pieces of awning rail on the brackets.

- Drill (1) 13/64" hole in the lower part of the back of the case in line with the center of each bracket. Carefully drill (1) 11/64" hole into the face of each bracket and attach the case to the brackets with the (2) #10 x 5/8" Phillips Head screws provided. Take care not to twist the head of the screw off when running screw into bracket.

**NOTE: CARE SHOULD BE TAKEN WHILE DRILLING IN ORDER TO PREVENT DAMAGE TO THE VEHICLE BODY!**

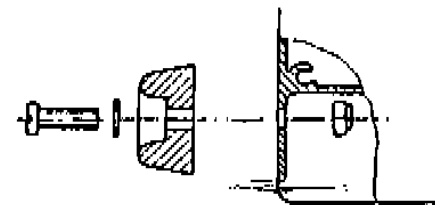
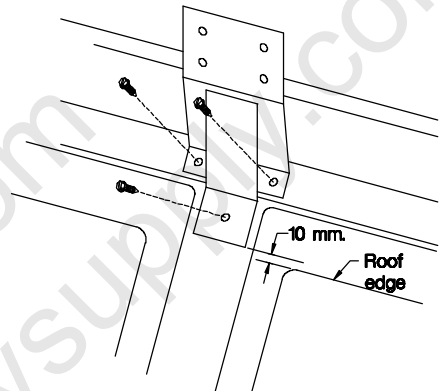
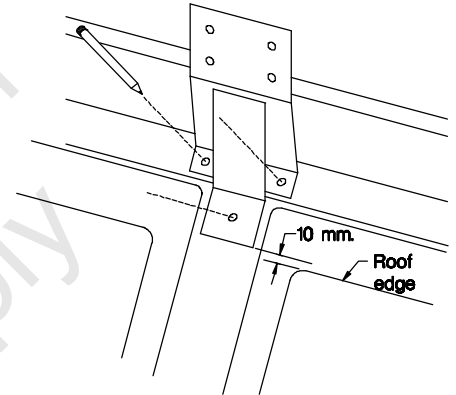

# OPERATING INSTRUCTIONS

**READ ENTIRE INSTRUCTIONS BEFORE BEGINNING OPERATION. READ ALL CAUTIONS, WARNINGS AND NOTE TO PREVENT INJURY OR DAMAGE TO AWNING OR VEHICLE.**

## SECTION III: OPERATION

### 1. TO EXTEND AWNING

- A. Press upward on the lock on the left and right hand side of awning housing cover.
- B. Unroll awning to complete extension.
- C. Remove one secondary support arm from lead bar by pulling downward on the carport foot located toward the center of the rail. Unlock gray flipper latch located on the support arm at the opposite end of the carport foot.
- D. Swing the arm assembly down and place in the vertical position with the foot resting on the ground. Adjust the height of the support arm and lock into place. (Lock into place by pushing the flipper latch downward past center until it is almost parallel with the arm.)

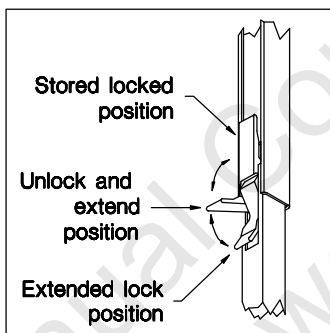

- E. Repeat with opposite end support arm assembly.
- F. Release upper brace from lead bar and extend upward. Place the end of the upper braces into the square hole in the rubber pad inside the box and pull and tension fabric.
- G. Extend brace outward until fabric is tight. Lock into place by pushing the flipper latch past center until it is almost parallel with the rafter assembly. (Place brace in box as shown to the right)

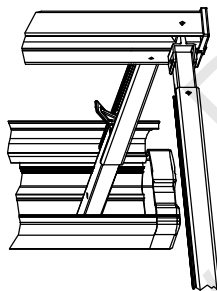

### 2. TO CLOSE AWNING

- A. Lower awning down to its lowest position by releasing the flipper latch on the support arm assembly. **CAUTION: ONCE THE FLIPPER LATCH IS RELEASED, THE SUPPORT ARM WILL WANT TO SLIDE DOWNWARD QUICKLY. TAKE CARE TO KEEP HANDS AWAY FROM ANY POSSIBLE PINCH POINT WHEN LOWERING SUPPORT ARM!**
- B. Remove One upper brace assembly from the case. Collapse brace assembly completely and store in lead rail.
- C. Repeat with opposite brace assembly.
- D. Remove carport stakes from one lower arm assembly, pivot arms upward and store in lead rail.
- E. Repeat with opposite arm.
- F. Grasp lead rail and roll fabric up to the stored position inside of case. **LEAD RAIL MUST ROLL OVER FABRIC.**
- G. Close housing cover. Make sure both left and right side locks are engaged.

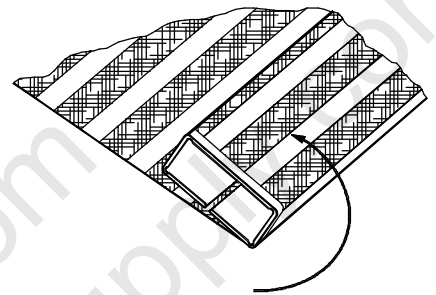
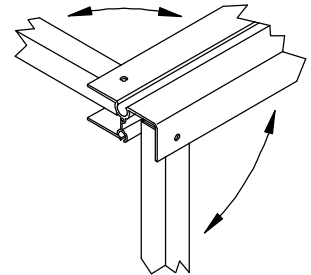

## SECTION IV: CARE AND MAINTENANCE

### 1. CARE OF FABRIC

Mildew will not form on the awning material itself, but may form on the dust allowed to accumulate on the canopy. A quality vinyl cleaner such as Carefree Awning Magic will keep your vinyl awning looking like new. Follow instructions on container.

**NOTE: ALLOW CANOPY TO DRY COMPLETELY BEFORE ROLLING AWNING UP.**

Metal surfaces should be cleaned with warm soapy solution and thoroughly rinsed.

### 2. PERIODIC MAINTENANCE

Like any other part of the RV, an owner should periodically inspect the awning. The following items should be checked.

- A. All mounting screws are tight.
- B. Check all pivot points for enlargements of holes or broken rivets.
- C. Check that the awning rail is tight against coach and all screws are tight.
- D. Check canopy for loose stitching and possible shrinkage.

## SECTION V: WARRANTY

Know your rights and responsibilities before operating this product! Please read the "limited" warranty provisions below carefully. Improper operation and maintenance, abuse, neglect, etc., will void your warranty.

### CAREFREE OF COLORADO LIMITED WARRANTY

#### 1. Duration: Sidewinder II

One year from the date of the original purchase.

#### 2. Who gives the warranty?

Carefree of Colorado, A Scott Fetzer Company (the "Company").

#### 3. Who receives this warranty?

The original purchaser (the "purchaser"), other than for purposes of resale, of a Sidewinder II. This warranty is not transferable.

#### 4. What is covered under this warranty?

- A. Repair or replacement at no charge, parts found by Company to be defective, provided that Company receives notice of the defect within one year from date of original purchase.
- B. Payment of reasonable labor charges for one year (Days) and reasonable freight expenses for 90 Days that may be incurred as a result of installing a replacement part, provided the Company receives notice of defect within one year from date of original purchase. Charges for travel time and mileage will not be allowed.

#### 5. What is NOT covered under this warranty?

- A. IMPLIED WARRANTIES, INCLUDING THOSE OF MERCHANTABILITY AND FITNESS FOR PARTICULAR PURPOSE, ARE LIMITED TO ONE YEAR FROM DATE OF ORIGINAL PURCHASE OF THE SIDEWINDER II. LIABILITY FOR INDIRECT OR CONSEQUENTIAL DAMAGES FOR ANY INCIDENTAL EXPENSES, UNDER ANY AND ALL WARRANTIES IS EXCLUDED. Some states do not allow limitation on how long an implied warranty lasts, or do not allow the exclusion or limitation of incidental or consequential damages, so the above limitations may not apply to you.

- B. Any failure that results from accident, wind or rain, purchaser's abuse, neglect, improper maintenance, or failure to operate and use the product in accordance with the instructions provided in the owner's manual supplied with this product.
  - C. Any failure that results from improper installation of the product.
  - D. Any component not sold or manufactured by the company.
6. Responsibilities of the Purchaser under this warranty:
- A. Must provide dated proof of purchase to the Company to qualify for any credits under provisions for coverage.
  - B. Promptly notify the dealer, or alternately, the Company of any claim hereunder. No work or parts to be replaced under warranty until Carefree has been notified and authorization has been given.
  - C. At the option of the Company, return the product or part to Carefree of Colorado for inspection. The dealer or purchaser must contact the Customer Service Department, 2145 W. 6th Avenue, Broomfield, Colorado 80020, Tele. (303) 469-3324, to receive a "Returned Goods Authorization" BEFORE any product or part is returned.
  - D. All freight expenses to and from Company must be borne by the Purchaser, except under the provisions of paragraph 4B above for Sidewinder II.
  - E. In addition to returning defective parts as described above, the Purchaser shall have the option of requesting the Company to ship replacement parts to Purchaser at the full retail price of the parts. Upon determination by the Company that the original parts are defective, Company will notify Purchaser of such determination and will issue credit due to Purchaser. (This option will minimize the period of time during which purchaser is unable to use the product.)
  - F. Use reasonable care in maintenance, operation, in accordance with the instructions contained in the owner's manual. This warranty gives you specific legal rights, and you may also have other rights which vary from state to state. The warranty does not cover damage to the product while traveling.

**Carefree  
of Colorado**

A Scott Fetzer Company  
2145 W. 6th Ave.  
Broomfield, Co. 80020  
(303) 469-3324

This Manual is Compliments of

# Northwest RV Supply

86325 College View Road  
Eugene, OR 97405

Local: 541-746-9092

Toll-Free: 866-678-7467

Fax: 541-736-5573

<http://www.nwrvsupply.com>  
[mail@nwrvsupply.com](mailto:mail@nwrvsupply.com)

Northwest RV Supply carries a large spectrum of surplus, used, and new RV parts and components. Please feel free to visit our website for additional information.